

FIELD CONNECTION INPUTS (OPTO-ISOLATED)
 EXTERNAL RELAY CONTROL:
 CONNECT TO BATTERY
 COMMON TO ENERGIZE RELAY

* OPTIONAL RELAY BOARD
 IF SPECIFIED ON ORDER

ALL RELAY CONTACTS SHOWN
 IN THE UNENERGIZED STATE
 CONTACTS ARE RATED 10 AMPS @ 125VAC
 CONTROL SWITCH IS IN 'AUTO' POSITION

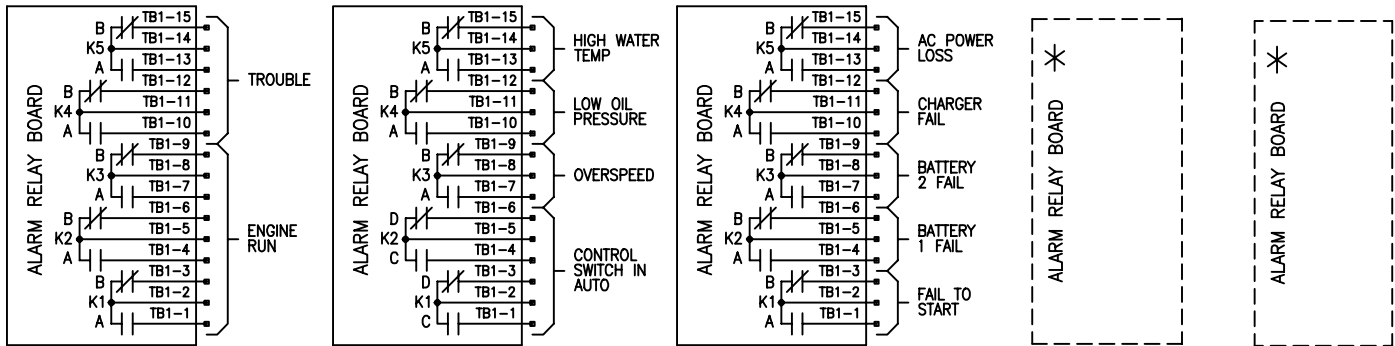
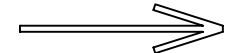

- WIRE SIZES -

USE #14 AWG WIRE MINIMUM FOR ALL ELECTRICAL CONNECTIONS EXCEPT AS SHOWN IN TABLE BELOW FOR BATTERY CHARGER

| FROM TERMINALS 6,7,8 AND 11 TO TERMINAL BLOCK ON ENGINE LINEAR FEET OF WIRE | MINIMUM WIRE SIZE |
|---|-------------------|
| UP TO 25' (7.62m) | #10 AWG |
| 25' TO 50' (7.62m-15.24m) | #8 AWG |

ALL RELAY CONTACTS SHOWN IN THE UNENERGIZED STATE
 CONTACTS "A" CLOSE TO ALARM
 CONTACTS "B" OPEN TO ALARM
 CONTACTS "C" CLOSED IN AUTO/TEST MODE
 CONTACTS "D" CLOSED IN OFF/MANUAL MODE

| E | D | C | B | A | Rev | DATE | BY | DESCRIPTION | LINEAR | HOLE | ANGLES | STANDARD FIELD CONNECTION LX-3000 DIESEL ENGINE FIRE PUMP CONTROLLER 12 OR 24 VOLTS DC | | | | | |
|--|---|---|---|---|-----|------|----|---------------|-------------------|-------------|-------------|--|---------------------------|---------------|-------|---------|------|
| | | | | | | | | | 0.X = ±.050 | PUNCH ±.002 | DIMEN. ± 1" | CADD NO. 30AF0011 | Disk No. LEXINGTO\ LX3000 | DATE 12/14/02 | DR.TR | CK.DAMA | REF. |
| | | | | | | | | 0.XX = ±.020 | DRILL ≤ .50 ±.004 | UNDIM. | | | | | | | |
| | | | | | | | | 0.XXX = ±.005 | DRILL > .50 ±.008 | 90° ±2' | | | | | | | |
| Hubbell Industrial Controls, Inc. 4301 Cheyenne Drive, Archdale, N.C. 27263 | | | | | | | | | DRG. NO. 1 OF 1 | | | A-30AF0011 | | | | | |